

## SELECTIVE MOBILE PALLET RACKING

Standard racking is mounted on powered mobile bases to form banks of mobile racks that can be operated by only one aisle. The racks are electronically powered and moved to enable a FLT to access every aisle when needed. Remote control panels can assist by linking FLT movements to throughputs. Specially constructed floors with running and guide rails are needed. Powered mobile is usually conceived at the planning stage and is used extensively in cold storage applications. High capacity and high usage close to 100% is common.

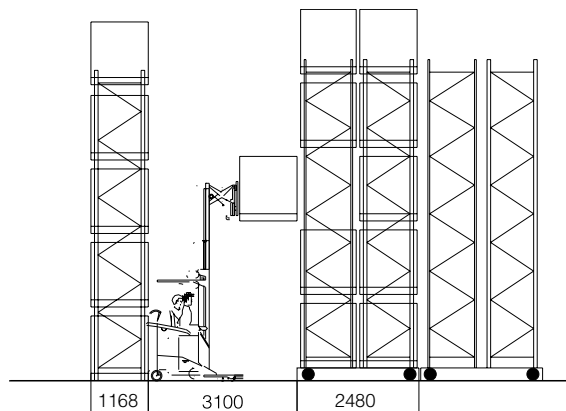
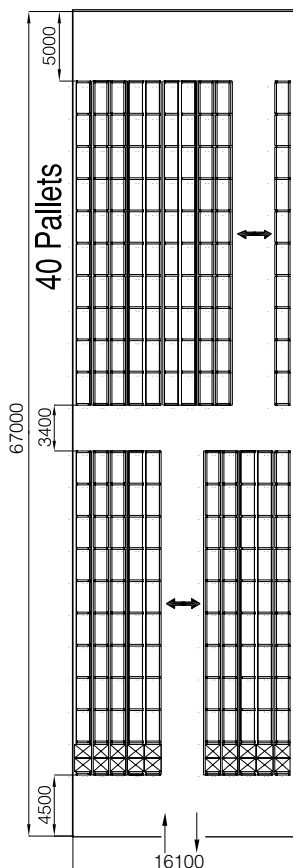
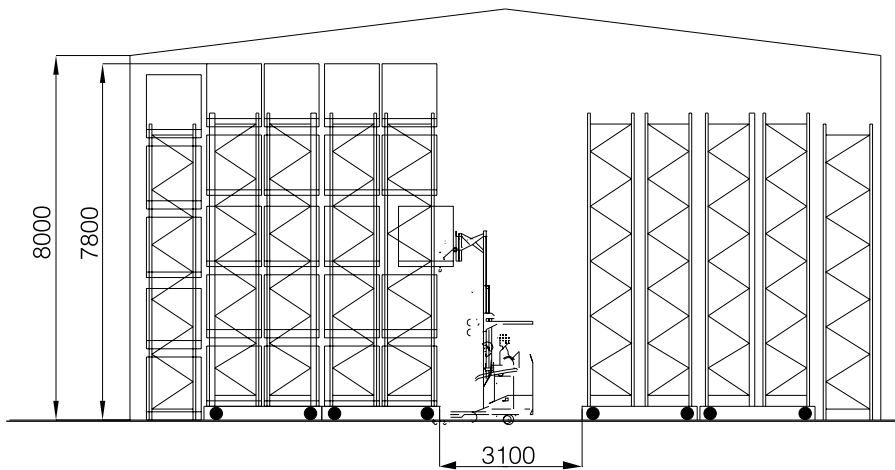

### Advantages

- △ Very dense storage with individual selectivity still available
- △ Product security and safety provided (possible to lock the system)
- △ Accessibility needs to be planned, especially using a remote control
- △ Safety systems of the scheme well established and exceed all international standards
- △ Materials handling equipment can be conventional

Pallet and Load Size :  
1165mm (Entry) x 1165 x  
1350mm (H)

Floor Area :  
67m x 16.1m = 1078 sqm

Total Building Volume :  
8630 cbm (8m High)

Average Floor Area/Pallet Position :  
1079 sqm/2000 Pallets =  
0.54 sqm/Pallet Position

Average Building  
Volume/Pallet Position :  
8630 cbm/2000 Pallets =  
4.315 cbm/Pallet

### SELECTIVE MOBILE RACKING FOR 2000 PALLETS

# SELECTIVE MOBILE PALLET RACKING

